



Excellent Performances & Reliability

CPD15F8/20F8/25F8

Four-wheel Electric Forklift 1.5/2.0/2.5t

Continuous 8-hour Operation
Charging-free for Heavy-duty Shift.

PROFEN EARTHMOVING TRADING L.L.C

www.forkliftuae.com

Four-wheel Electric Forklift 1.5/2.0/2.5t CPD15F8/CPD20F8/25F8

Distinguishing mark						
1.1	Manufacturer			PROLIFT	PROLIFT	PROLIFT
1.2	Model designation			CPD15F8	CPD20F8	CPD25F8
1.3	Drive unit			Electrics	Electrics	Electrics
1.4	Operator type			seated	seated	seated
1.5	rated capacity	Q	kg	1500	2000	2500
1.6	Load center distance	c	mm	500	500	500
1.8	Load distance, centre of drive axle to fork	x	mm	413	456	456
1.9	Wheelbase	y	mm	1400	1500	1500
Weight						
2.1	Service weight		kg	3050	3860	4030
2.2	Axle loading, laden front/ rear		kg	3899/651	5350/510	5930/600
2.3	Axle loading, unladen front/ rear		kg	1485/1565	1770/2090	1800/2230
Tyre, type						
3.1	Tyre type			pneumatic	pneumatic	pneumatic
3.2	Tyre size, front			6.5-10-10PR	23×9-10	23×9-10
3.3	Tyre size, rear			5.00-8-10PR	18X7-8	18X7-8
3.5	Wheels, number front/ rear (x=drive wheels)		mm	2x/ 2	2x/ 2	2x/ 2
3.6	Tread, front	b ₁₀	mm	890	1045	1045
3.7	Tread, rear	b ₁₁	mm	920	950	950
Dimensions						
4.1	Tilt of mast/fork carriage forward/backward	α/β (°)		6/ 12	6/11	6/11
4.2	Height, mast lowered	h ₁	mm	2098	1985	1985
4.3	Free lift	h ₂	mm	120	120	120
4.4	Lift height	h ₃	mm	3000	3000	3000
4.5	Height, mast extended	h ₄	mm	4010	4010	4010
4.7	Height of overhead guard (cabin)	h ₆	mm	2098	2180	2180
4.8	Seat height/standing height	h ₇	mm	1053	1105	1105
4.12	Tow coupling height	h ₁₀	mm	390	305	305
4.19	Overall length	l ₁	mm	3090	3416	3416
4.20	Length to face of forks	l ₂	mm	2170	2346	2346
4.21	Overall width	b ₁ /b ₂	mm	1080	1252	1252
4.22	Fork dimensions	s/e/l	mm	40×100×920	40×120×1070	40×120×1070
4.23	Fork carriage class/type A, B			—	2A	2A
4.24	Fork carriage width	b ₃	mm	1085	1085	1085
4.31	Ground clearance, laden, below mast	m ₁	mm	120	110	110
4.32	Ground clearance, center of wheelbase	m ₂	mm	110	125	125
4.34.1	Aisle width for pallets 1000 × 1200 crossways	Ast	mm	3658	3791	3791
4.34.2	Aisle width for pallets 800 × 1200 crossways	Ast	mm	3858	3991	3991
4.35	turning radius	Wa	mm	2045	2135	2135
Performance data						
5.1	Travel speed, laden/ unladen		km/ h	14/14.5	13/ 13.5	13/ 13.5
5.2	Lifting speed, laden/ unladen		m/ s	0.3/0.45	0.3/ 0.45	0.3/ 0.45
5.3	Lowering speed, laden/ unladen		m/ s	0.45/0.44	0.44/ 0.435	0.44/ 0.435
5.5	Drawbar pull, laden/unladen		N	—	—	—
5.6	Max. drawbar pull, laden/unladen		N	11000	17000	17000
5.7	Gradeability, laden/unladen		%	—	—	—
5.8	Max. gradeability, laden/unladen		%	10.5/14	10.5/14	10.5/14
5.9	Acceleration time, laden/unladen		s	Hydraulic / Mechanical	Hydraulic+Mechanical	Hydraulic+Mechanical
5.10	Service brake			Mechanical	Mechanical	Mechanical
Electric-engine						
6.1	Drive motor rating S2 60 min		kW	8	11	11
6.2	Lift motor rating at S3 15%		kW	11	13	13
6.3	Battery according to DIN 43531 /35 / 36 A, B, C, no			—	—	—
6.4	Battery voltage/nominal capacity K5		V/Ah	48/400	48/600(Max770)	48/630(Max770)
6.5	Battery weight		kg	780	940	1044
Addition data						
8.1	Type of drive unit			AC	AC	AC
10.5	Steering type			—	—	—
10.7	Sound pressure level at the driver's ear		dB (A)	70	71	71

If there are improvements of technical parameters or configurations, no further notice will be given.
The diagram shown may contain non-standard configurations.

Mast Option

CPD15F8

Tpye	Model	Max.fork height h3	Overall height				Free lift		Front Overhang X		Tilt range		Capacity	
			Lowered h1	Extended		Without backrest	With backrest h2	FWD α			BWD β	Load capacity at 500 mm		
				Without backrest	With backrest h4				Single tire					
			mm	mm	mm	mm	mm	mm	mm	mm	Deg	Deg	kg	kg
Wide view mast	2W200	2000	1480	2510	3010	120	120	413	413	6	12	1500	1800	
	2W250	2500	1730	3010	3510	120	120	413	413	6	12	1500	1800	
	2W270	2700	1830	3210	3710	120	120	413	413	6	12	1500	1800	
	2W300	3000	1980	3510	4010	120	120	413	413	6	12	1500	1800	
	2W330	3300	2130	3810	4310	120	120	413	413	6	12	1500	1800	
	2W350	3500	2230	4010	4510	120	120	413	413	6	12	1500	1800	
	2W360	3600	2280	4110	4610	120	120	413	413	6	12	1500	1800	
	2W400	4000	2530	4510	5010	120	120	413	413	6	12	1400	1600	
	2W430	4300	2680	4810	5310	120	120	413	413	6	6	1300	1500	
2W450	4500	2780	5010	5510	120	120	413	413	6	6	1250	1400		
wide view full 2-stage mast	2F250	2500	1765	3010	3510	1255	755	413	413	6	12	1500	1800	
	2F270	2700	1865	3210	3710	1355	855	413	413	6	12	1500	1800	
	2F300	3000	2015	3510	4010	1505	1005	413	413	6	12	1500	1800	
	2F330	3300	2165	3810	4310	1655	1155	413	413	6	12	1500	1800	
	2F360	3600	2315	4110	4610	1805	1305	413	413	6	12	1500	1800	
	2F400	4000	2515	4510	5010	2005	1505	413	413	6	12	1400	1700	
wide view full 3-stage mast	3F430	4300	1985	4810	5310	1475	975	440	440	6	6	1250	1450	
	3F450	4500	2035	5010	5510	1525	1025	440	440	6	6	1200	1350	
	3F480	4800	2135	5310	5810	1625	1125	440	440	6	6	1100	1250	
	3F500	5000	2200	5510	6010	1690	1190	440	440	6	6	1050	1150	
	3F550	5500	2370	6010	6510	1860	1360	440	440	3	6	/	900	
	3F600	6000	2585	6510	7010	2075	1575	440	440	3	6	/	/	

CPD20F8/25F8

Tpye	Model	Max.fork height h3	Overall height				Free lift		Front Overhang X		Tilt range		Capacity	
			Lowered h1	Extended		Without backrest	With backrest h2	FWD α			BWD β	Load capacity at 500 mm		
				Without backrest	With backrest h4				Single tire					
			mm	mm	mm	mm	mm	mm	mm	mm	Deg	Deg	kg	kg
Wide view mast	2W200	2000	1485	2685	3010	120	120	456	456	6	11	2000	2500	
	2W250	2500	1735	3185	3510	120	120	456	456	6	11	2000	2500	
	2W270	2700	1835	3385	3710	120	120	456	456	6	11	2000	2500	
	2W300	3000	1985	3685	4010	120	120	456	456	6	11	2000	2500	
	2W330	3300	2135	3985	4310	120	120	456	456	6	11	2000	2500	
	2W350	3500	2235	4185	4510	120	120	456	456	6	11	2000	2500	
	2W360	3600	2285	4285	4610	120	120	456	456	6	11	2000	2500	
	2W400	4000	2535	4685	5010	120	120	456	456	6	11	1900	2300	
	2W430	4300	2685	4985	5310	120	120	456	456	6	6	1800	2100	
2W450	4500	2785	5185	5510	120	120	456	456	6	6	1700	2000		
wide view full 2-stage mast	2F250	2500	1770	3205	3510	1065	760	456	456	6	11	2000	2500	
	2F270	2700	1870	3405	3710	1165	860	456	456	6	11	2000	2500	
	2F300	3000	2030	3705	4010	1325	1020	456	456	6	11	2000	2500	
	2F330	3300	2170	4005	4310	1465	1160	456	456	6	11	2000	2500	
	2F360	3600	2330	4305	4610	1625	1320	456	456	6	11	2000	2500	
	2F400	4000	2580	4705	5010	1875	1570	456	456	6	11	1900	2300	
wide view full 3-stage mast	3F430	4300	2020	5000	5310	1320	1010	456	456	6	6	1700	2000	
	3F450	4500	2100	5200	5510	1400	1090	500	500	6	6	1600	1900	
	3F480	4800	2205	5500	5810	1505	1195	500	500	6	6	1500	1700	
	3F500	5000	2290	5700	6010	1590	1280	500	500	6	6	1400	1600	
	3F550	5500	2540	6200	6510	1840	1530	500	500	3	6	1050	1200	
	3F600	6000	2790	6700	7010	2090	1780	500	500	3	6	700	800	

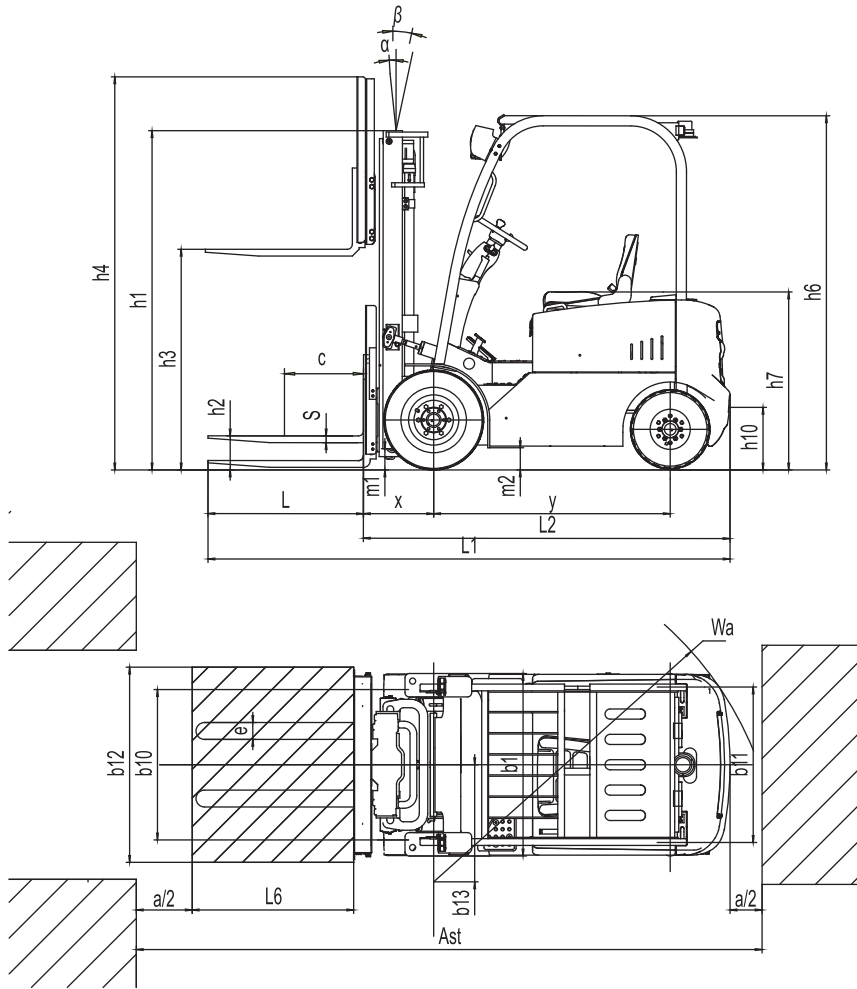

CPD15F8
RATED CAPACITIES GRAPH

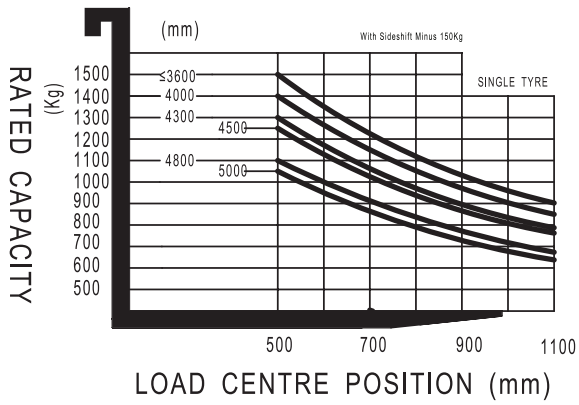

CPD20F8
RATED CAPACITIES GRAPH

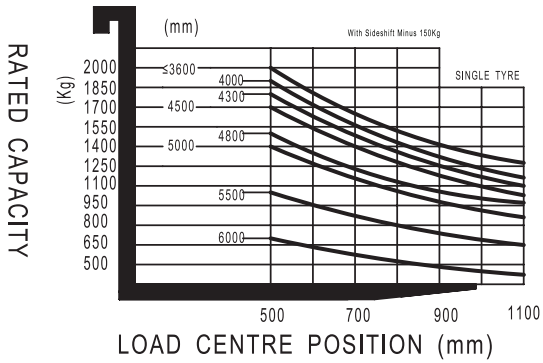

CPD25F8
RATED CAPACITIES GRAPH

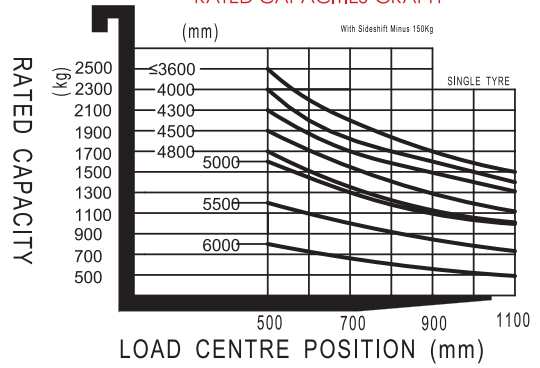



Option

Options			CPD15F8	CPD20F8/25F8
1	Fork length		○	○
2	Fold fork		○	—
3	Battery capacity		○	○
4	Import battery		○	○
5	Solid rubber tire		○	○
6	Environmental solid tire		○	○
7	Cold storage		○	○
8	Lateral change battery		○	○
9	fork weighing system		○	○
10	Overhead guard		○	○
11	Mast options		○	○
12	Attachments		○	○
13	Built in side shift		○	○
14	Proportional valve		—	—
17	Light	LED front light	●	●
28		Back light	○	○
22		Warning light	●	●
18	Fire extinguisher		○	○
19	Water auto-fillingsystem		○	○
20	Seat		○	○
21	Seat switch		○	○
23	Cockpit	With fan heater	○	○
25		With front windshield wiper	○	○
26		With rear windshield wiper	○	○
16		Cockpit	○	○
24	Doulbe front wheel		—	—
27	Rearview		●	○
29	OPS system		○	○
30	Backrest width		○	○
31	Environmental solid tire		○	○
32	Air fan		○	○
33	Charging voltage		○	○
35	Drive-in Rack		○	○

Note: ● standard ○ option — NA

Repair & Maintenance Workshop

For Heavy Equipment & Machinery



Our state-of-the-art workshop, located in Al Saja'a Industrial Area, Sharjah, is an excellent support to our experienced and reliable outdoor technicians. Not only is it's location easily accessible from all Northern Emirates, but it is also fully equipped with the requisite tools and tackles to ensure a professional and flawless repair job. So the next time you have a repair, troubleshooting, maintenance or component overhaul job on your hydraulic rock breakers, forklifts or hydraulic components, **Professional Engineers Workshop** is the place to go.

Deisel and Electric Forklift Trucks

- Forklift Repair and Maintenance
- Major and Minor Servicing
- Annual Maintenance Contracts
- Electric Forklift Fault-finding
- Engine Overhauling
- Transmission Overhauling
- Hydraulic Components: Repair and Overhauling



Construction Equipment and Machinery

- Hydraulic Rock Breaker: Repair and Overhauling
- Hydraulic Oil Flow and Pressure Testing
- Welding and Fabrication of Heavy Construction Machinery Attachments
- Light Construction Machinery Repair



Hydraulic Hose: Mobile Workshop

Keeping a machine, vehicle or any heavy earthmoving equipment down, for the sake of a failed hydraulic hose or leaking connector, it is not only hard on the pocket, it is literally a crime! Coming to the rescue, is our **mobile hydraulic hose cutting & crimping workshop**.

With trained and experienced technicians, available round the clock, 24/7, literally at your doorstep in Tawyeen area, is a service which is unparalleled in terms of time economy and value for money. Needless to say, the quality of our hoses and fittings are impeccable.



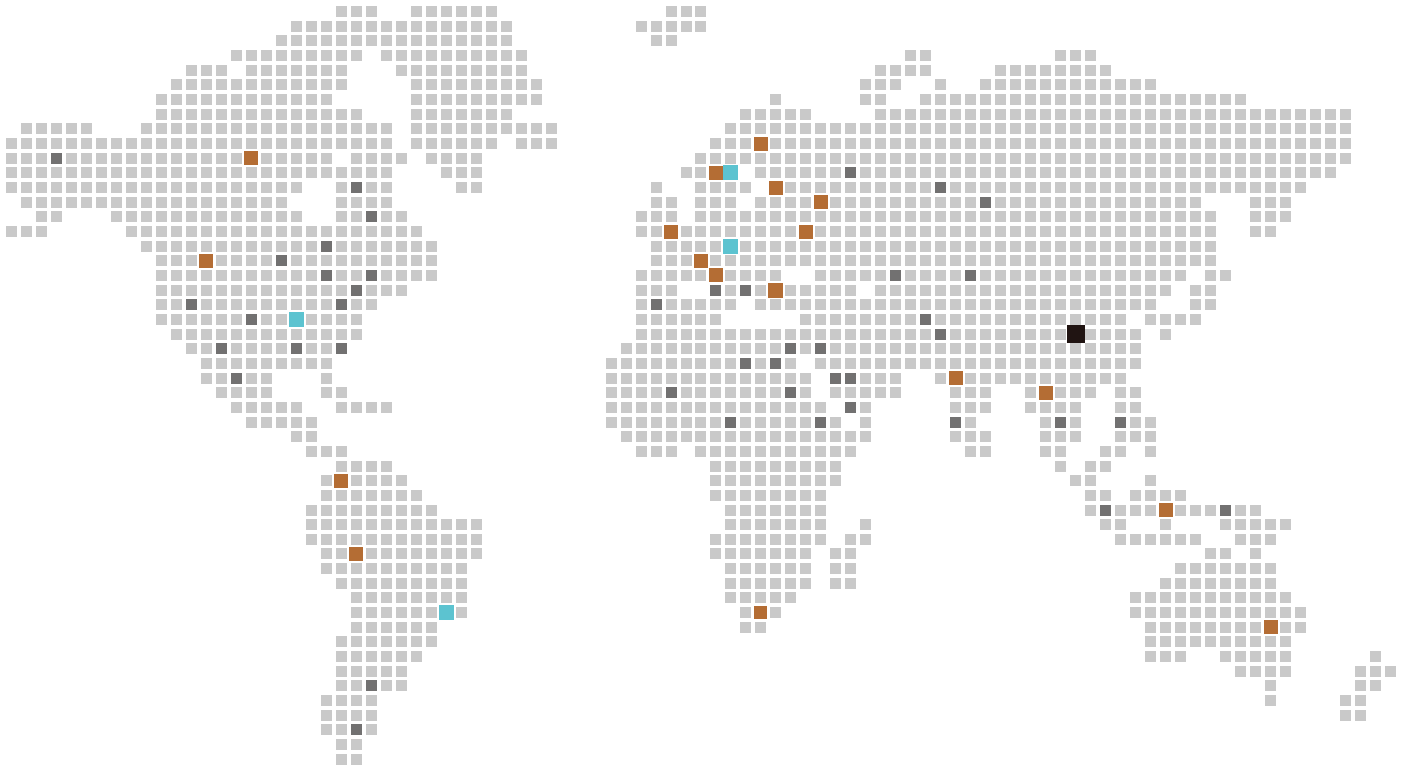

PROFEN EARTHMOVING TRD. L.L.C

P.O.Box : 181926, Dubai-U.A.E

E-mail : mustafa@profenuae.com

Website: construction.profenuae.com

Tel : +971 6 531 9779

Mob : +971 50 823 7395

Mob : +971 56 728 6192



Professional Engineers Workshop

For Heavy Equipment & Machinery Maintenance L.L.C

Shed 56, Behind Sharjah, Cement Factory Al Saja'a
Industrial Area, Sharjah - U.A.E

Tel: +971 6 742 5229 / +971 54 586 7297

E-mail: admin@profenworkshop.com

Webiste: www.profenworkshop.com